

# DCE 2008 SOLVED PAPER

THIS PAPER HAS BEEN TAKEN FROM "Disha's DCE Solved Papers"



## PHYSICS

1. The primary and secondary coils of a transformer have 50 and 1500 turns respectively. If the magnetic flux  $\phi$  linked with the primary coil is given by  $\phi = \phi_0 + 4t$ , where  $\phi$  is in weber,  $t$  is time in second and  $\phi_0$  is a constant, the output voltage across the secondary coil is  
(a) 90 V (b) 120 V  
(c) 220 V (d) 30 V
2. A particle executes simple harmonic oscillation with an amplitude  $a$ . The period of oscillation is  $T$ . The minimum time taken by the particle to travel half of the amplitude from the equilibrium position is  
(a)  $\frac{T}{4}$  (b)  $\frac{T}{8}$   
(c)  $\frac{T}{12}$  (d)  $\frac{T}{2}$
3. In the energy band diagram of a material shown below, the open circles and filled circles denote holes and electrons respectively. The material is a/an
- 
- (a)  $p$  type semiconductor  
(b) insulator  
(c) metal  
(d)  $n$ -type semiconductor
4. Two radioactive substances A and B have decay constant  $5\lambda$  and  $\lambda$  respectively. At  $t = 0$  they have the same number of nuclei. The ratio of number of nuclei of A to those of B will be  $\left(\frac{1}{e}\right)^2$  after a time interval  
(a)  $\frac{1}{4\lambda}$  (b)  $4\lambda$   
(c)  $2\lambda$  (d)  $\frac{1}{2\lambda}$
5. A charged particle (charge  $q$ ) is moving in a circle of radius  $R$  with uniform speed  $v$ . The associated magnetic moment  $\mu$  is given by  
(a)  $\frac{qvR}{2}$  (b)  $qvR^2$   
(c)  $\frac{qvR^2}{2}$  (d)  $qvR$
6. A wire mesh consisting of very small squares is viewed at a distance of 8 cm through a magnifying converging lens of focal length 10 cm, kept close to the eye. The magnification produced by the lens is  
(a) 5 (b) 8  
(c) 10 (d) 20
7. Hard X-rays for the study of fractures in bones should have a minimum wavelength of  $10^{-11}$  m. The accelerating voltage for electrons in X-ray machine should be  
(a)  $< 124$  kV  
(b)  $> 124$  kV  
(c) between 60 kV and 70 kV  
(d)  $= 100$  kV
8. In photoelectric effect, the electrons are ejected from metals if the incident light has a certain minimum  
(a) wavelength (b) frequency  
(c) amplitude (d) angle of incidence
9. A lens is made of flint glass (refractive index = 1.5). When the lens is immersed in a liquid of refractive index 1.25, the focal length :  
(a) increases by a factor of 1.25  
(b) increases by a factor of 2.5  
(c) increases by a factor of 1.2  
(d) decreases by a factor of 1.2
10. The voltage of clouds is  $4 \times 10^6$  V with respect to ground. In a lightning strike lasting 100 ms, a charge of 4 C is delivered to the ground. The power of lightning strike is  
(a) 160 MW (b) 80 MW  
(c) 20 MW (d) 500 KW
11. A point source emits sound equally in all directions in a non-absorbing medium. Two points P and Q are at distance of 2 m and 3 m respectively from the source. The ratio of the intensities of the waves at P and Q is  
(a) 9 : 4 (b) 2 : 3  
(c) 3 : 2 (d) 4 : 9

12. For inelastic collision between two spherical rigid bodies
- the total kinetic energy is conserved
  - the total mechanical energy is not conserved
  - the linear momentum is not conserved
  - the linear momentum is conserved
13. When a  $p-n$  junction diode is reverse biased, then
- no current flows
  - the depletion region is increased
  - the depletion region is reduced
  - the height of the potential barrier is reduced
14. A person used force (F), shown in figure to move a load with constant velocity on given surface.

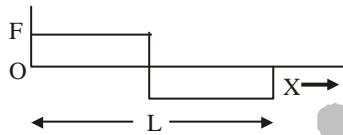

Identify the correct surface profile

- 
- 
- 
- 

15. Flash light equipped with a new set of batteries, produces bright white light. As the batteries wear out
- the light intensity gets reduced with no change in its colour
  - light colour changes first to yellow and then red with no change in intensity
  - it stops working suddenly while giving white light
  - colour changes to red and also intensity gets reduced

16. The spatial distribution of the electric field due to charges (A, B) is shown in figure. Which one of the following statements is correct?

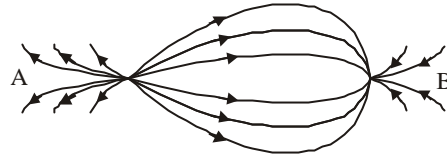

- A is +ve and B -ve and  $|A| > |B|$
  - A is -ve and B +ve;  $|A| = |B|$
  - Both are +ve but  $A > B$
  - Both are -ve but  $A > B$
17.  ${}_{92}^{238}\text{U}$  has 92 protons and 238 nucleons. It decays by emitting an alpha particle and becomes
- ${}_{92}^{234}\text{U}$
  - ${}_{90}^{234}\text{Th}$
  - ${}_{92}^{235}\text{U}$
  - ${}_{93}^{237}\text{Np}$
18. The fossil bone has a  ${}^{14}\text{C} : {}^{12}\text{C}$  ratio, which is  $\left[\frac{1}{16}\right]$  of that in a living animal bone. If the half-life of  ${}^{14}\text{C}$  is 5730 years, then the age of the fossil bone is
- 11460 years
  - 17190 years
  - 22920 years
  - 45840 years

19. Which one of the following is a possible nuclear reaction?

- ${}_{5}^{10}\text{B} + {}_{2}^{4}\text{He} \longrightarrow {}_{7}^{12}\text{N} + {}_{1}^{1}\text{H}$
- ${}_{11}^{23}\text{Na} + {}_{1}^{1}\text{H} \longrightarrow {}_{10}^{20}\text{Ne} + {}_{2}^{4}\text{He}$
- ${}_{93}^{239}\text{Np} \longrightarrow {}_{94}^{239}\text{Pu} + \beta^{-} + \bar{\nu}$
- ${}_{7}^{14}\text{N} + {}_{1}^{1}\text{H} \longrightarrow {}_{6}^{12}\text{C} + \beta^{-} + \bar{\nu}$

20. Two tuning forks P and Q when set vibrating, give 4 beats/s. If a prong of the fork P is filed, the beats are reduced to 2/s. What is frequency of P, if that of Q is 250 Hz?
- 246 Hz
  - 250 Hz
  - 254 Hz
  - 252 Hz

21. If alpha, beta and gamma rays carry same momentum, which has the longest wavelength?
- Alpha rays
  - Beta rays
  - Gamma rays
  - None, all have same wavelength

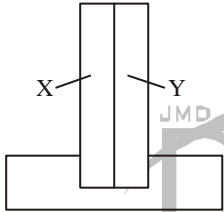
22. An amplifier has a voltage gain  $A_v = 1000$ . The voltage gain in dB is :
- (a) 30 dB (b) 60 dB  
(c) 3 dB (d) 20 dB
23. When you make ice cubes, the entropy of water
- (a) does not change  
(b) increases  
(c) decreases  
(d) may either increase or decrease depending on the process used
24. A bimetallic strip consists of metals X and Y. It is mounted rigidly at the base as shown. The metal X has a higher coefficient of expansion compared to that for metal Y. When bimetallic strip is placed in a cold bath
- 
- (a) it will bend towards the right  
(b) it will bend towards the left  
(c) it will not bend but shrink  
(d) it will neither bend nor shrink
25. A leaf which contains only green pigments, is illuminated by a laser light of wavelength  $0.6328 \mu\text{m}$ . It would appear to be
- (a) brown (b) black  
(c) red (d) green
26. The minimum potential difference between the base and emitter required to switch a silicon transistor 'ON' is approximately
- (a) 1 V (b) 3 V  
(c) 5 V (d) 4.2 V
27. If the cold junction of a thermocouple is kept at  $0^\circ\text{C}$  and the hot junction is kept at  $T^\circ\text{C}$ , then the relation between neutral temperature ( $T_n$ ) and temperature of inversion ( $T_i$ ) is
- (a)  $T_n = \frac{T_i}{2}$  (b)  $T_n = 2T_i$   
(c)  $T_n = T_i - T$  (d)  $T_n = T_i + T$
28. In radioactive decay process, the negatively charged emitted  $\beta$ -particles are
- (a) the electrons present inside the nucleus  
(b) the electrons produced as a result of the decay of neutrons inside the nucleus  
(c) the electrons produced as a result of collision between atoms  
(d) the electrons orbiting around the nucleus
29. A particle starting from the origin (0, 0) moves in a straight line in the (x, y) plane. Its coordinates at a later time are  $(\sqrt{3}, 3)$ . The path of the particle makes with the x-axis an angle of
- (a)  $30^\circ$  (b)  $45^\circ$   
(c)  $60^\circ$  (d)  $0^\circ$
30. The resistance of an ammeter is  $13\Omega$  and its scale is graduated for a current upto 100 A. After an additional shunt has been connected to this ammeter it becomes possible to measure currents upto 750 A by this meter. The value of shunt resistance is
- (a)  $20\Omega$  (b)  $2\Omega$   
(c)  $0.2\Omega$  (d)  $2k\Omega$
31. Two spheres of same size, one of mass 2 kg and another of mass 4 kg, are dropped simultaneously from the top of Qutab Minar (height = 72 m). When they are 1 m above the ground, the two spheres have the same
- (a) momentum (b) kinetic energy  
(c) potential energy (d) acceleration
32. The moment of inertia of a rod about an axis through its centre and perpendicular to it is  $\frac{1}{12} ML^2$  (where M is the mass and L, the length of the rod). The rod is bent in the middle so that the two halves make an angle of  $60^\circ$ . The moment of inertia of the bent rod about the same axis would be
- (a)  $\frac{1}{48} ML^2$  (b)  $\frac{1}{12} ML^2$   
(c)  $\frac{1}{24} ML^2$  (d)  $\frac{ML^2}{8\sqrt{3}}$
33. A boat at anchor is rocked by waves whose crests are 100 m apart and velocity is 25 m/s. The boat bounces up once in every
- (a) 2500 s (b) 75 s  
(c) 4 s (d) 0.25 s

34. By sucking through a straw, a student can reduce the pressure in his lungs to 750 mm of Hg (density = 13.6 g/cm<sup>3</sup>). Using the straw, he can drink water from a glass upto a maximum depth of
- (a) 10 cm (b) 75 cm  
(c) 13.6 cm (d) 1.36 cm
35. Two parallel large thin metal sheets have equal surface charge densities ( $\sigma = 26.4 \times 10^{-12} \text{C/m}^2$ ) of opposite signs. The electric field between these sheets is
- (a) 1.5 N/C (b)  $1.5 \times 10^{-10} \text{N/C}$   
(c) 3 N/C (d)  $3 \times 10^{-10} \text{N/C}$
36. A particle of mass  $m$  moves in the XY plane with a velocity  $v$  along the straight line AB. If the angular momentum of the particle with respect to origin O is  $L_A$  when it is at A and  $L_B$  when it is at B, then

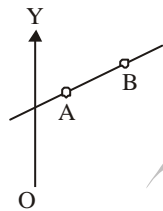

- (a)  $L_A > L_B$   
(b)  $L_A = L_B$   
(c) the relationship between  $L_A$  and  $L_B$  depends upon the slope of the line AB  
(d)  $L_A < L_B$
37. A mass of 2.0 kg is put on a flat pan attached to a vertical spring fixed on the ground as shown in the figure. The mass of the spring and the pan is negligible. When pressed slightly and released the mass executes a simple harmonic motion. The spring constant is 200 N/m. What should be the minimum amplitude of the motion, so that the mass gets detached from the pan? (Take  $g = 10 \text{m/s}^2$ )

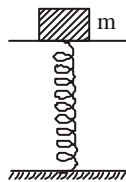

- (a) 8.0 cm  
(b) 10.0 cm  
(c) Any value less than 12.0 cm  
(d) 4.0 cm

38. A beam of electrons passes undeflected through mutually perpendicular electric and magnetic fields. If the electric field is switched off, and the same magnetic field is maintained, the electrons move
- (a) in an elliptical orbit  
(b) in a circular orbit  
(c) along a parabolic path  
(d) along a straight line
39. The phase difference between the instantaneous velocity and acceleration of a particle executing simple harmonic motion is
- (a)  $0.5\pi$  (b)  $\pi$   
(c)  $0.707\pi$  (d) zero
40. Dimensions of resistance in an electrical circuit, in terms of dimension of mass M, of length L, of time T and of current I, would be
- (a)  $[ML^2T^{-3}I^{-1}]$  (b)  $[ML^2T^{-2}]$   
(c)  $[ML^2T^{-1}I^{-1}]$  (d)  $[ML^2T^{-3}I^{-2}]$
41. Specific rotation of sugar solution is 0.01 SI units. 200 kg m<sup>-3</sup> of impure sugar solution is taken in a polarimeter tube of length 0.25 m and an optical rotation of 0.4 rad is observed. The percentage of purity of sugar in the sample is
- (a) 11% (b) 20%  
(c) 80% (d) 89%
42. When a body falls in air, the resistance of air depends to a great extent on the shape of the body. Three different shapes are given. Identify the combination of air resistances which truly represents the physical situation?

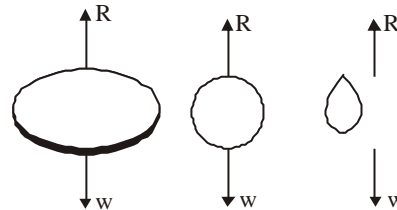

- (1) disc (2) ball (3) cigar shaped  
(The cross-sectional areas are the same).
- (a)  $1 < 2 < 3$  (b)  $2 < 3 < 1$   
(c)  $3 < 2 < 1$  (d)  $3 < 1 < 2$
43. A beam of parallel rays is brought to focus by a plano-convex lens. A thin concave lens of the same focal length is joined to the first lens. The effect of this is
- (a) the focus shifts to infinity  
(b) the focal point shifts towards the lens by a small distance  
(c) the focal point shifts away from the lens by a small distance  
(d) the focus remains undisturbed

44. Identify the wrong description of the below figures

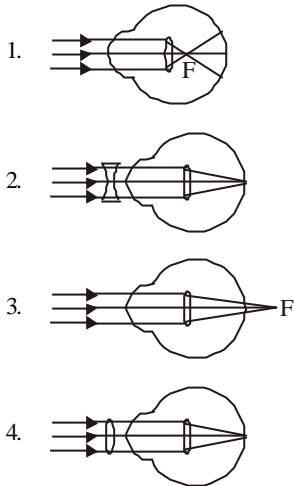

- (a) 1 represents far sightedness
- (b) 2 correction for short sightedness
- (c) 3 represents far sightedness
- (d) 4 correction for far sightedness

45. The figure below shows the plot of  $\frac{pV}{nT}$  versus  $p$  for oxygen gas at two different temperatures.

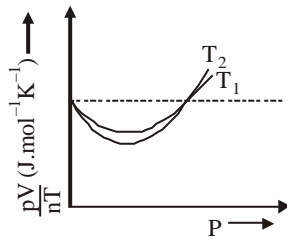

Read the following statements concerning the above curves

- (i) The dotted line corresponds to the 'ideal' gas behaviour
- (ii)  $T_1 > T_2$
- (iii) the value of  $\frac{pV}{nT}$  at the point where the curves meet on the y-axis is the same for all gases.

Which of the above statements is true?

- (a) (i) only
- (b) (i) and (ii) only
- (c) All of the above
- (d) None of these

46. A ray of light is incident on the surface of a glass plate of thickness  $t$ . If the angle of incidence  $\theta$  is small, the emerging ray would be displaced side ways by an amount (Take  $n$  = refractive index of glass)

- (a)  $t\theta n/(n+1)$
- (b)  $t\theta (n-1)/n$
- (c)  $t\theta n/(n-1)$
- (d)  $t\theta (n+1)/n$

47. An asteroid of mass  $m$  is approaching earth, initially at a distance of  $10R_e$  with speed  $v_i$ . It hits the earth with a speed  $v_f$  ( $R_e$  and  $M_e$  are radius and mass of earth), then

- (a)  $v_f^2 = v_i^2 + \frac{2Gm}{M_e R} \left(1 - \frac{1}{10}\right)$
- (b)  $v_f^2 = v_i^2 + \frac{2Gm_e}{R_e} \left(1 + \frac{1}{10}\right)$
- (c)  $v_f^2 = v_i^2 + \frac{2Gm_e}{R_e} \left(1 - \frac{1}{10}\right)$
- (d)  $v_f^2 = v_i^2 + \frac{2Gm}{R_e} \left(1 - \frac{1}{10}\right)$

48. In the figure, a proton moves a distance  $d$  in a uniform electric field as  $\vec{E}$  shown in the figure. Does the electric field do a positive or negative work on the proton? Does the electric potential energy of the proton increase or decrease?

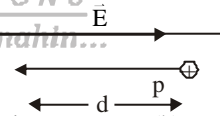

- (a) - ve, increase
- (b) + ve, increase
- (c) - ve, decrease
- (d) + ve, decrease

49. The figure shows three circuits with identical batteries, inductors and resistance. Rank the circuits according to the currents through the battery just after the switch is closed, greatest first.

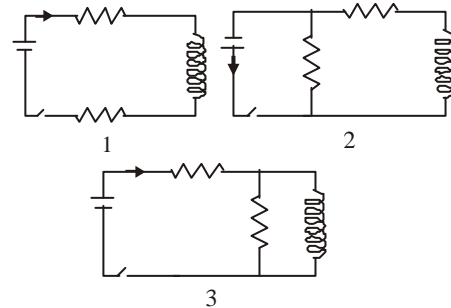

- (a)  $i_2 > i_3 > i_1$
- (b)  $i_2 > i_1 > i_3$
- (c)  $i_1 > i_2 > i_3$
- (d)  $i_1 > i_3 > i_2$

50. The figure shows the path of a positively charged particle 1 through a rectangular region of uniform electric field as shown in the figure. What is the direction of electric field and the direction of deflection of particles 2, 3 and 4?

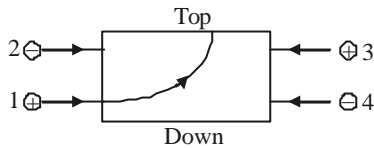

- (a) Top; down, top, down  
 (b) Top; down, down, top  
 (c) Down; top, top, down  
 (d) Down; top, down, down
51. A spherical ball of mass 20 kg is stationary at the top of a hill of height 100 m. It rolls down a smooth surface to the ground, then climbs up another hill of height 30 m and finally rolls down to a horizontal base at a height of 20 m above the ground. The velocity attained by the ball is  
 (a) 40 m/s (b) 20 m/s  
 (c) 10 m/s (d)  $10\sqrt{30}$  m/s
52. A sound absorber attenuates the sound level by 20 dB. The intensity decreases by a factor of  
 (a) 1000 (b) 10000  
 (c) 10 (d) 100
53. A parallel plate capacitor is made by stacking  $n$  equally spaced plates connected alternatively. If the capacitance between any two adjacent plates is  $C$ , then the resultant capacitance is  
 (a)  $(n-1)C$  (b)  $(n+1)C$   
 (c)  $C$  (d)  $nC$
54. A six pole generator with fixed field excitation develops an emf of 100 V, when operating at 1500 rpm. At what speed must it rotate to develop 120 V?  
 (a) 1200rpm (b) 1800rpm.  
 (c) 1500rpm (d) 400 rpm
55. Energy from the sun is received on earth at the rate of 2 cal per  $\text{cm}^2$  per min. If average wavelength of solar light be taken at  $5500 \text{ \AA}$  then how many photons are received on the earth per  $\text{cm}^2$  per min?  
 ( $h = 6.6 \times 10^{-34} \text{ J-s}$ ,  $1 \text{ cal} = 4.2 \text{ J}$ ).  
 (a)  $1.5 \times 10^{13}$  (b)  $2.9 \times 10^{13}$   
 (c)  $2.3 \times 10^{19}$  (d)  $1.75 \times 10^{19}$
56. A beam of 35.0 keV electrons strikes a molybdenum target, generating the X-rays. What is the cutoff wavelength?  
 (a) 35.5 pm (b) 40.0 pm  
 (c) 15.95 pm (d) 18.2 pm
57. We have seen that a gamma-ray dose of 3 Gy is lethal to half the people exposed to it. If the equivalent energy were absorbed as heat, what rise in body temperature would result?  
 (a) 300  $\mu\text{K}$  (b) 700  $\mu\text{K}$   
 (c) 455  $\mu\text{K}$  (d) 390  $\mu\text{K}$
58. Mass spectrometric analysis of potassium and argon atoms in a Moon rock sample shows that the ratio of the number of (stable)  $^{40}\text{K}$  atoms present to the number of (radioactive)  $^{40}\text{K}$  atoms is 10.3. Assume that all the argon atoms were produced by the decay of potassium atoms, with a half life of  $1.25 \times 10^9 \text{ yr}$ . How old is the rock?  
 (a)  $2.95 \times 10^{11} \text{ yr}$  (b)  $2.95 \times 10^9 \text{ yr}$   
 (c)  $4.37 \times 10^9 \text{ yr}$  (d)  $4.37 \times 10^{11} \text{ yr}$
59. A particle is thrown above, then correct v-t graph will be
- (a)

(b)
- (c)

(d)
60. The speed ( $v$ ) of ripples on the surface of water depends on surface tension ( $\sigma$ ), density ( $\rho$ ) and wavelength ( $\lambda$ ). The square of speed ( $v$ ) is proportional to  
 (a)  $\frac{\sigma}{\rho\lambda}$  (b)  $\frac{\rho}{\sigma\lambda}$   
 (c)  $\frac{\lambda}{\sigma\rho}$  (d)  $\rho\lambda\sigma$

## CHEMISTRY

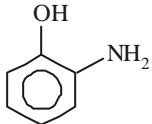
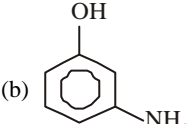
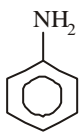
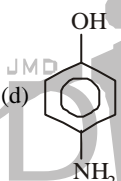
61. Which of the following dissolves in water but does not give any oxyacid solution?  
 (a)  $\text{SO}_2$  (b)  $\text{OF}_2$   
 (c)  $\text{SCl}_4$  (d)  $\text{SO}_3$
62. Which of the following is a favourable factor for cation formation?  
 (a) Low ionisation potential  
 (b) High electron affinity  
 (c) High electronegativity  
 (d) Small atomic size
63. Which of the following gives paracetamol on acetylation?
- (a) 
- (b) 
- (c) 
- (d) 
64. A mixture of amylose and amylopectin is called  
 (a) lactose (b) starch  
 (c) cellulose (d) sucrose
65. 1, 2-dibromoethane reacts with alcoholic KOH to yield a product X. The hybridisation state of the carbons present in X respectively, are  
 (a)  $sp, sp$  (b)  $sp^3, sp^3$   
 (c)  $sp^3, sp^2$  (d)  $sp^3, sp^2$
66. Which one of the following is used for reviving the exhausted 'permutit'?  
 (a) HCl solution  
 (b) 10%  $\text{CaCl}_2$  solution  
 (c) 10%  $\text{MgCl}_2$  solution  
 (d) 10% NaCl solution
67. Which one of the following is a lyophilic colloidal solution?  
 (a) smoke  
 (b) Gold sol  
 (c) Starch aqueous solution  
 (d) Cloud
68. Xenon hexafluoride reacts with silica to form a xenon compound X. The oxidation state of xenon in X is  
 (a) +2 (b) +4  
 (c) +6 (d) 0
69. When oxyhaemoglobin changes to deoxyhaemoglobin,  $\text{Fe}^{2+}$  ion changes from  
 (a) diamagnetic to paramagnetic  
 (b) paramagnetic to diamagnetic  
 (c) diamagnetic to ferromagnetic  
 (d) paramagnetic to ferromagnetic
70. The noble gas used in atomic reactor, is  
 (a) krypton (b) oxygen  
 (c) neon (d) helium
71. Acidified  $\text{KMnO}_4$  oxidises oxalic acid to  $\text{CO}_2$ . What is the volume (in litres) of  $10^{-4}$  M  $\text{KMnO}_4$  required to completely oxidise 0.5 L of  $10^{-2}$  M oxalic acid in acid medium?  
 (a) 125 (b) 1250  
 (c) 200 (d) 20
72. The total number of electrons present in all the 's' orbitals, all the 'p' orbitals and all the 'd' orbitals of cesium ion are respectively  
 (a) 8, 26, 10 (b) 10, 24, 20  
 (c) 8, 22, 24 (d) 12, 20, 22
73. Nitrobenzene is reduced by Zn and alcoholic potash mixture to get  
 (a)  $\text{C}_6\text{H}_5-\text{NH}_2$   
 (b)  $\text{C}_6\text{H}_5-\text{NH}-\text{NH}-\text{C}_6\text{H}_5$   
 (c)  $\text{C}_6\text{H}_5-\text{N}=\text{N}-\text{C}_6\text{H}_5$   
 (d)  $\text{C}_6\text{H}_5-\text{NH}-\text{CO}-\text{C}_6\text{H}_5$
74. Ethyl orthoformate is formed by heating ..... with sodium ethoxide.  
 (a)  $\text{CHCl}_3$  (b)  $\text{C}_2\text{H}_5\text{OH}$   
 (c)  $\text{HCOOH}$  (d)  $\text{CH}_3\text{CHO}$
75. Which one of the following compounds is prepared in the laboratory from benzene by a substitution reaction?  
 (a) Glyoxal  
 (b) Cyclohexane  
 (c) Acetophenone  
 (d) Hexabromocyclohexane
76. The atomicity of phosphorus is X and the PPP bond angle in the molecule is Y. What are X and Y?  
 (a)  $X=4, Y=90^\circ$  (b)  $X=4, Y=60^\circ$   
 (c)  $X=3, Y=120^\circ$  (d)  $X=2, Y=180^\circ$
77. The electron affinity values (in  $\text{kJ mol}^{-1}$ ) of three halogens X, Y and Z are respectively - 349, -333 and - 325. Then X, Y and Z respectively are  
 (a)  $\text{F}_2, \text{Cl}_2$  and  $\text{Br}_2$  (b)  $\text{Cl}_2, \text{F}_2$  and  $\text{Br}_2$   
 (c)  $\text{Cl}_2, \text{Br}_2$  and  $\text{F}_2$  (d)  $\text{Br}_2, \text{Cl}_2$  and  $\text{F}_2$

78. If 50% of a radioactive substance dissociates in 15 min, then the time taken by substance to dissociate 99% will be  
 (a) 50min (b) 100 min  
 (c) 99min (d) 150 min
79. The rate of chemical reaction doubles for every 10°C increase in temperature, if the temperature of reaction is increased from 30°C to 80°C. The rate of reaction increases  
 (a) 16 times (b) 32 times  
 (c) 64 times (d) 4 times
80. The bond angle in  $\text{AsH}_3$  is greater than that in  
 (a)  $\text{NH}_3$  (b)  $\text{H}_2\text{O}$   
 (c)  $\text{BCl}_3$  (d) None of these
81. Which of the following is not correct?  
 (a) Enthalpy of physical adsorption is less compared to enthalpy of chemical adsorption  
 (b) Milk is an example of emulsion  
 (c) Physical adsorption increases with the increase in temperature  
 (d) Smoke is an aerosol
82. Acetylene and HCHO react in presence of copper acetylide catalyst to form  
 (a) 1-butyne-1, 4-diol  
 (b) 2-butyne-1, 2-diol  
 (c) 2-butyne-1, 4-diol  
 (d) None of the above
83. The best method to separate the mixture of *ortho*- and *para* nitrophenol (1 : 1) is  
 (a) vaporisation (b) colour spectrum  
 (c) distillation (d) crystallisation
84. *t*-butyl chloride preferably undergo hydrolysis by  
 (a)  $\text{S}_{\text{N}}1$  mechanism (b)  $\text{S}_{\text{N}}2$  mechanism  
 (c) Any of (a) and (b) (d) None of the above
85. What is the amount of urea dissolved per litre if its aqueous solution is isotonic with 10% cane sugar solution? (mol. wt. of urea = 60)  
 (a) 200 g/L (b) 19.2 g/L  
 (c) 17.54 g/L (d) 16.7 g/L
86. Which of the following has lowest boiling point?  
 (a) NaCl (b) CuCl  
 (c)  $\text{CuCl}_2$  (d) CsCl
87. Sodium metal crystallises at room temperature in a body centred cubic lattice with a cell edge  $a = 4.29 \text{ \AA}$ . The radius of sodium atom is  
 (a) 1.40 (b) 2.65  
 (c) 1.85 (d) 2.15
88. The most probable velocity (in cm/s) of hydrogen molecule at 27°C, will be  
 (a)  $19.3 \times 10^4$  (b)  $17.8 \times 10^4$   
 (c)  $24.93 \times 10^9$  (d)  $17.8 \times 10^8$
89. Which has maximum paramagnetic character?  
 (a)  $[\text{Fe}(\text{CN})_6]^{4-}$  (b)  $[\text{Cu}(\text{H}_2\text{O}_4)]^{2+}$   
 (c)  $[\text{Cu}(\text{NH}_3)_4]^{2+}$  (d)  $[\text{Mn}(\text{H}_2\text{O})_6]^{2+}$
90. Which of the following is not a member of 3d-transition series?  
 (a) Fe (b) Co  
 (c) Au (d) Cu
91. The half life of two samples are 0.1 and 0.8 s. Their respective concentration are 400 and 50 respectively. The order of the reaction is  
 (a) 0 (b) 2  
 (c) 1 (d) 4
92. Which of the following has got incompletely filled *f* subshell?  
 (a) Gadolinium (b) Lutetium  
 (c) Lawrencium (d) Tantalum
93. The cell reaction of the galvanic cell  $\text{Cu}(\text{s}) | \text{Cu}^{2+}(\text{aq}) || \text{Hg}^{2+}(\text{aq}) | \text{Hg}(\ell)$  is  
 (a)  $\text{Hg} + \text{Cu}^{2+} \rightarrow \text{Hg}^{2+} + \text{Cu}$   
 (b)  $\text{Hg} + \text{Cu}^{2+} \rightarrow \text{Cu}^+ + \text{Hg}^+$   
 (c)  $\text{Cu} + \text{Hg} \rightarrow \text{CuHg}$   
 (d)  $\text{Cu} + \text{Hg}^{2+} \rightarrow \text{Cu}^{2+} + \text{Hg}$
94. If the standard electrode potential of  $\text{Cu}^{2+}/\text{Cu}$  electrode is 0.34 V, what is the electrode potential at 0.01 M concentration of  $\text{Cu}^{2+}$ ? ( $T = 298 \text{ K}$ )  
 (a) 0.399 V (b) 0.281 V  
 (c) 0.222 V (d) 0.176 V
95. What is the number of free electrons present on each carbon atom in graphite?  
 (a) zero (b) 3  
 (c) 2 (d) 1
96. At 600°C,  $K_p$  for the following reaction is 1 atm.  

$$\text{X}(\text{g}) \rightleftharpoons \text{Y}(\text{g}) + \text{Z}(\text{g})$$
 At equilibrium, 50% of X (g) is dissociated. The total pressure of the equilibrium system is *p* atm. What is the partial pressure (in atm) of X (g) at equilibrium?  
 (a) 1 (b) 4  
 (c) 2 (d) 0.5
97. In which part of atmosphere, ozone layer is present?  
 (a) Stratosphere (b) Troposphere  
 (c) Mesosphere (d) Thermosphere

98. Which of the following is not correct regarding the electrolytic preparation of  $H_2O_2$ ?
- Lead is used as cathode
  - 50%  $H_2SO_4$  is used
  - Hydrogen is liberated at anode
  - Sulphuric acid undergoes oxidation
99. Which of the following is correct?
- In the Castner's process of sodium extraction, NaCl is used as an electrolyte
  - Sodium reduces  $CO_2$  to carbon
  - Mg reacts with cold water and liberate hydrogen gas
  - Magnalium is an alloy of Mg and Zn
100.  $N_2(g) + 3H_2(g) \rightleftharpoons 2NH_3(g) + 22\text{kcal}$ . The activation energy for the forward reaction is 50 kcal. What is the activation energy for the backward reaction?
- 72 kcal
  - 28 kcal
  - +28 kcal
  - +72 kcal
101. A compound X undergoes reduction with  $LiAlH_4$  to yield Y. When vapours of Y are passed over freshly reduced copper at  $300^\circ C$ , X is formed. What is Y?
- $CH_3COCH_3$
  - $CH_3CHO$
  - $CH_3CH_2OH$
  - $CH_3OCH_3$
102. Wet ether is not used as a solvent in Wurtz reaction, because the water present in it
- hydrolyses RX to ROH
  - reduces RX to RH
  - destroy the Na metal
  - reacts with R-R
103. The product formed in the aldol condensation of acetaldehyde is
- $CH_3CH_2CH(OH)CHO$
  - $CH_3CH(OH)CH_2CHO$
  - $CH_3CH(OH)COCH_3$
  - $CH_3CH_2CH_2CHO$
104. What is the lowest energy of the spectral line emitted by the hydrogen atom in the Lyman series?  
( $h$  = Planck's constant,  $c$  = velocity of light,  $R$  = Rydberg's constant)
- $\frac{5hcR}{36}$
  - $\frac{4hcR}{3}$
  - $\frac{3hcR}{4}$
  - $\frac{7hcR}{144}$
105. 100 mL of 0.015 M HCL solution is mixed with 100 mL of 0.005 M HCL. What is the pH of the resultant solution?
- 2.5
  - 1.5
  - 2
  - 1
106. Which one of the following is an exothermic reaction?
- $N_2(g) + O_2(g) + 180.8\text{ kJ} \rightarrow 2NO(g)$
  - $N_2(g) + 3H_2(g) - 92\text{ kJ} \rightarrow 2NH_3(g)$
  - $C(g) + H_2O(g) \rightarrow CO(g) + H_2(g) - 131.1\text{ kJ}$
  - $C(\text{graphite}) + 2S(s) \rightarrow CS_2(l) - 91.9\text{ kJ}$
107. One of the elements present in carnalite shows flame colouration. The colour of the flame is
- orange
  - green
  - yellow
  - lilac
108. If the boiling point of ethanol (molecular weight = 46) is  $78^\circ C$ , what is the boiling point of diethyl ether? (molecular weight = 74)
- $100^\circ C$
  - $78^\circ C$
  - $86^\circ C$
  - $34^\circ C$
109. Aniline reacts with ..... to yield .... as the final product.
- bromine, 2-bromo aniline
  - bromine, 2, 4, 6-tribromoaniline
  - chloroform / KOH, phenyl cyanide
  - acetyl chloride, benzanilide
110. The values of four quantum number of valence electron of an element are  $n = 4$ ,  $m = 0$ ,  $l = 0$  and  $s = +\frac{1}{2}$ . The element is
- K
  - Ti
  - Na
  - Sc
111. In the reactions
- $$B \xleftarrow{\text{Lindlar catalyst}/H_2} RC \equiv CR \xrightarrow[H_2]{Na/NH_3} A$$
- A and B are geometrical isomers. Then,
- A is *cis* and B is *trans*
  - A is *trans* and B is *cis*
  - A and B are *cis*
  - A and B are *trans*
112. Lanthanide contraction is due to increase in
- shielding by 4 *f*-electrons
  - atomic number
  - effective nuclear charge
  - size of 4 *f* orbitals
113. Which of the following is currently used as tyre cord?
- Polyethylene
  - Polypropylene
  - Bakelite
  - Nylon-6

114. Synthetic petrol is prepared by

- (a) Wurtz reaction  
 (b) by distillation  
 (c) Fisher-Tropsch process  
 (d) None of the above

115. Ethylene glycol reacts with excess of  $\text{PCl}_5$  to give

- (a) 1, 1-dichloroethane  
 (b) 1, 2-dichloroethane  
 (c) 1, 1, 1-trichloroethane  
 (d) 2, 2-dichloroethane

116. Orbital interaction between the  $\sigma$ -bonds of a substituent group and a neighbouring  $\pi$  orbital is known as

- (a) hyperconjugation  
 (b) inductive effect  
 (c) steric effect  
 (d) electric quadrupole interactions

117. The absolute configuration of the following

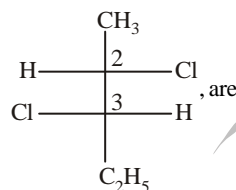

- (a) 2 S, 3 R  
 (b) 2 S, 3 S  
 (c) 2 R, 3 S  
 (d) 2 R, 3 R

118. The free energy change for the following reactions are given below.

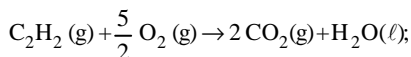

$$\Delta G^\circ = -1234 \text{ kJ}$$

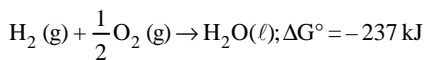
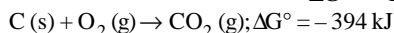

What is the standard free energy change for the reaction

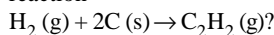

- (a) -209 kJ  
 (b) -2259 kJ  
 (c) +2259 kJ  
 (d) 209 kJ

119. The solubility of  $\text{AgCl}$  in 0.2 M  $\text{NaCl}$  is ( $K_{sp}$  of  $\text{AgCl} = 1.8 \times 10^{-10}$ )

- (a)  $1.8 \times 10^{-11} \text{ M}$   
 (b)  $9 \times 10^{-10} \text{ M}$   
 (c)  $6.5 \times 10^{-12} \text{ M}$   
 (d)  $5.6 \times 10^{-11} \text{ M}$

120. Which of the following is a heterocyclic amino acid?

- (a) Glycine  
 (b) Alanine  
 (c) Phenylalanine  
 (d) Tryptophan

## MATHEMATICS

121. The root of the equation  $1 - \cos \theta = \sin \theta \sin \frac{\theta}{2}$ 

is

- (a)  $k\pi, k \in \mathbb{I}$   
 (b)  $2k\pi, k \in \mathbb{I}$   
 (c)  $k\frac{\pi}{2}, k \in \mathbb{I}$   
 (d) None of these

122. In the expansion of  $\frac{e^{7x} + e^{3x}}{e^{5x}}$ , the constant term

is

- (a) 0  
 (b) 1  
 (c) 2  
 (d) None of these

123.  $\frac{C_0}{1} + \frac{C_2}{3} + \frac{C_4}{5} + \frac{C_6}{7} + \dots$  is equal to

- (a)  $\frac{2^{n+1}}{n+1}$   
 (b)  $\frac{2^{n+1}-1}{n+1}$   
 (c)  $\frac{2^n}{n+1}$   
 (d) None of these

124. How many numbers lying between 999 and 10000 can be formed with the help of the digit 0, 2, 3, 6, 7, 8 when the digit are not be repeated

- (a) 100  
 (b) 200  
 (c) 300  
 (d) 400

125. Let two numbers have arithmetic mean 9 and geometric mean 4. Then these numbers are the roots of the quadratic equation

- (a)  $x^2 - 18x - 16 = 0$   
 (b)  $x^2 - 18x + 16 = 0$   
 (c)  $x^2 + 18x - 16 = 0$   
 (d)  $x^2 + 18x + 16 = 0$

126. The line drawn from  $(4, -1, 2)$  to the point  $(-3, 2, 3)$  meets a plane at right angle at the point  $(-10, 5, 4)$ , then the equation of plane is

- (a)  $7x + 3y + z + 89 = 0$   
 (b)  $7x - 3y - z + 89 = 0$   
 (c)  $7x - 3y + z + 89 = 0$   
 (d) None of the above

127. The value of 'c' for which  $|\alpha^2 - \beta^2| = \frac{7}{4}$ , where $\alpha$  and  $\beta$  are the roots of  $2x^2 + 7x + c = 0$ , is

- (a) 0  
 (b) 2  
 (c) 4  
 (d) 6

128. The maximum value of

$$\cos^2\left(\frac{\pi}{3} - x\right) - \cos^2\left(\frac{\pi}{3} + x\right) \text{ is}$$

- (a)  $-\frac{\sqrt{3}}{2}$  (b)  $\frac{1}{2}$   
 (c)  $\frac{\sqrt{3}}{2}$  (d)  $\frac{3}{2}$

129. For the given circles  $x^2 + y^2 - 6x - 2y + 1 = 0$  and  $x^2 + y^2 + 2x - 8y + 13 = 0$  which of the following is true ?

- (a) One circle lies inside the other  
 (b) One circle lies completely outside the other  
 (c) Two circles intersect in two points  
 (d) They touch each other externally

130. The sum of the series

$$\frac{1}{1.2.3} + \frac{1}{3.4.5} + \frac{1}{5.6.7} + \dots \infty, \text{ is}$$

- (a)  $\log_e 2 - \frac{1}{2}$  (b)  $\log_e 2$   
 (c)  $\log_e 2 + \frac{1}{2}$  (d)  $\log_e 2 + 1$

131. Let A and B be two sets then  $(A \cup B) \cap (A' \cap B')$  is equal to

- (a)  $A'$  (b)  $A$   
 (c)  $B'$  (d) None of these

132. The domain of  $\sin^{-1}\left[\log_3\left(\frac{x}{3}\right)\right]$  is

- (a)  $[1, 9]$  (b)  $[-1, 9]$   
 (c)  $[-9, 1]$  (d)  $[-9, -1]$

133. If  $x^2 + 2ax + 10 - 3a > 0$  for all  $x \in \mathbb{R}$ , then

- (a)  $-5 < a < 2$  (b)  $a < -5$   
 (c)  $a > 5$  (d)  $2 < a < 5$

134.  $\int_0^2 \frac{x^3 dx}{(x^2 + 1)^{3/2}}$  is equal to

- (a)  $(\sqrt{2} - 1)^2$  (b)  $\frac{(\sqrt{2} - 1)^2}{\sqrt{2}}$   
 (c)  $\frac{\sqrt{2} - 1}{\sqrt{2}}$  (d) None of these

135.  $\int [\sin(\log x) + \cos(\log x)] dx$  is equal to

- (a)  $x \cos(\log x) + c$  (b)  $\sin(\log x) + c$   
 (c)  $\cos(\log x) + c$  (d)  $x \sin(\log x) + c$

136. The function  $f(x) = x(x+3)e^{-(1/2)x}$  satisfies all the conditions of Rolle's theorem in  $[-3, 0]$ . The value of c is

- (a) 0 (b) -1  
 (c) -2 (d) -3

137.  $f(x) = \left(\frac{e^{2x} - 1}{e^{2x} + 1}\right)$  is

- (a) an increasing (b) a decreasing  
 (c) an even (d) None of these

138. A house has multi-storeys. The lowest storey is 20 ft high. A stone which is dropped from the top of the house passes the lowest storey in  $1/4$  s. The height of the house is

- (a) 100ft (b) 110ft  
 (c) 110.25ft (d) None of these

139. A man is known to speak the truth 3 out of 4 times. He throws a die and reports that it is a six. The probability that it is actually a six, is

- (a)  $\frac{3}{8}$  (b)  $\frac{1}{5}$   
 (c)  $\frac{3}{4}$  (d) None of these

140. Two cards are drawn successively with replacement from a well shuffled deck of 52 cards, then the mean of the number of aces is

- (a)  $\frac{1}{13}$  (b)  $\frac{3}{13}$   
 (c)  $\frac{2}{13}$  (d) None of these

141. If the plane  $2ax - 3ay + 4az + 6 = 0$  passes through the midpoint of the line joining the centres of the spheres  $x^2 + y^2 + z^2 + 6x - 8y - 2z = 13$  and  $x^2 + y^2 + z^2 - 10x + 4y - 2z = 8$ , then a equals

- (a) -2 (b) 2  
 (c) -1 (d) 1

142. The projection of the line segment joining the points  $(-1, 0, 3)$  and  $(2, 5, 1)$  on the line whose direction ratios are  $(6, 2, 3)$  is

- (a)  $\frac{10}{7}$  (b)  $\frac{22}{7}$   
 (c)  $18/7$  (d) None of these

143. Vector coplanar with vectors  $\hat{i} + \hat{j}$  and  $\hat{j} + \hat{k}$  and parallel to the vector  $2\hat{i} - 2\hat{j} - 4\hat{k}$ , is  
 (a)  $\hat{i} - \hat{k}$  (b)  $\hat{i} - \hat{j} - 2\hat{k}$   
 (c)  $\hat{i} + \hat{j} - \hat{k}$  (d)  $3\hat{i} + 3\hat{j} - 6\hat{k}$
144. The circumcentre of a triangle formed by the line  $xy + 2x + 2y + 4 = 0$  and  $x + y + 2 = 0$ , is  
 (a)  $(-1, -1)$  (b)  $(0, -1)$   
 (c)  $(1, 1)$  (d)  $(-1, 0)$
145. The point P (a, b) lies on the straight line  $3x + 2y = 13$  and the point Q (b, a) lies on the straight line  $4x - y = 5$ , then equation of the line PQ is  
 (a)  $x - y = 5$  (b)  $x + y = 5$   
 (c)  $x + y = -5$  (d)  $x - y = -5$
146. The bisector of the acute angle formed between the lines  $4x - 3y + 7 = 0$  and  $3x - 4y + 14 = 0$  has the equation  
 (a)  $x + y + 3 = 0$  (b)  $x - y - 3 = 0$   
 (c)  $x - y + 3 = 0$  (d)  $3x + y - 7 = 0$
147. If the line  $y \cos \alpha = x \sin \alpha + a \cos \alpha$  be a tangent to the circle  $x^2 + y^2 = a^2$ , then  
 (a)  $\sin^2 \alpha = 1$  (b)  $\cos^2 \alpha = 1$   
 (c)  $\sin^2 \alpha = a^2$  (d)  $\cos^2 \alpha = a^2$
148. The point of intersection of the curves whose parametric equations are  $x = t^2 + 1, y = 2t$  and  $x = 2s, y = \frac{2}{s}$ , is given by  
 (a)  $(1, -3)$  (b)  $(2, 2)$   
 (c)  $(-2, 4)$  (d)  $(1, 2)$
149. The equation of the ellipse whose distance between the foci is equal to 8 and distance between the directrix is 18, is  
 (a)  $5x^2 - 9y^2 = 180$  (b)  $9x^2 + 5y^2 = 180$   
 (c)  $x^2 + 9y^2 = 180$  (d)  $5x^2 + 9y^2 = 180$
150. If  $\cos \theta = \frac{8}{17}$  and  $\theta$  lies in the 1st quadrant, then the value of  $\cos(30^\circ + \theta) + \cos(45^\circ - \theta) + \cos(120^\circ - \theta)$  is  
 (a)  $\frac{23}{17} \left( \frac{\sqrt{3}-1}{2} + \frac{1}{\sqrt{2}} \right)$   
 (b)  $\frac{23}{17} \left( \frac{\sqrt{3}+1}{2} + \frac{1}{\sqrt{2}} \right)$   
 (c)  $\frac{23}{17} \left( \frac{\sqrt{3}-1}{2} - \frac{1}{\sqrt{2}} \right)$   
 (d)  $\frac{23}{17} \left( \frac{\sqrt{3}+1}{2} - \frac{1}{\sqrt{2}} \right)$
151. The greatest term in the expansion of  $\sqrt{3} \left( 1 + \frac{1}{\sqrt{3}} \right)^{20}$  is  
 (a)  $\frac{26840}{9}$  (b)  $\frac{24840}{9}$   
 (c)  $\frac{25840}{9}$  (d) None of these
152. The amplitude of  $\sin \frac{\pi}{5} + i \left( 1 - \cos \frac{\pi}{5} \right)$  is  
 (a)  $\frac{2\pi}{5}$  (b)  $\frac{\pi}{15}$   
 (c)  $\frac{\pi}{10}$  (d)  $\frac{\pi}{5}$
153. A house subtends a right angle at the window of an opposite house and the angle of elevation of the window from the bottom of the first house is  $60^\circ$ . If the distance between the two houses be 6m, then the height of the first house is  
 (a)  $8\sqrt{3}m$  (b)  $6\sqrt{3}m$   
 (c)  $4\sqrt{3}m$  (d) None of these
154. All possible two factors products are formed from numbers 1, 2, 3, 4, ... 200. The number of factors out of the total obtained which are multiples of 5 is  
 (a) 5040 (b) 7180  
 (c) 8150 (d) None of these
155. If  $\vec{b}$  and  $\vec{c}$  are any two non-collinear unit vectors and  $\vec{a}$  is any vector, then  $(\vec{a} \cdot \vec{b}) \cdot \vec{b} + (\vec{a} \cdot \vec{c}) \cdot \vec{c} + \frac{\vec{a} \cdot (\vec{b} \times \vec{c})}{|\vec{b} \times \vec{c}|} \cdot (\vec{b} \times \vec{c})$  is equal to  
 (a)  $\vec{0}$  (b)  $\vec{a}$   
 (c)  $\vec{b}$  (d)  $\vec{c}$
156. The sum of the series  $1 + 3x + 6x^2 + 10x^3 + \dots \infty$  will be  
 (a)  $\frac{1}{(1-x)^2}$  (b)  $\frac{1}{1-x}$   
 (c)  $\frac{1}{(1+x)^2}$  (d)  $\frac{1}{(1-x)^3}$

$$157. \left| \frac{1}{2}(z_1 + z_2) + \sqrt{z_1 z_2} \right| + \left| \frac{1}{2}(z_1 + z_2) - \sqrt{z_1 z_2} \right|$$

is equal to

- (a)  $|z_1 + z_2|$  (b)  $|z_1 - z_2|$   
 (c)  $|z_1| + |z_2|$  (d)  $|z_1| - |z_2|$

$$158. \lim_{x \rightarrow 0} x \log_e(\sin x) \text{ is equal to}$$

- (a)  $-1$  (b)  $\log_e 1$   
 (c)  $1$  (d) None of these

159. The function defined by

$$f(x) = \begin{cases} \left( x^2 + e^{\frac{1}{2-x}} \right)^{-1} & x \neq 2 \\ k & , x = 2 \end{cases} \text{ is continuous}$$

from right at the point  $x = 2$ , then  $k$  is equal to

- (a)  $0$  (b)  $\frac{1}{4}$   
 (c)  $-\frac{1}{2}$  (d) None of these

$$160. \int \frac{dx}{\sin(x-a)\sin(x-b)} \text{ is}$$

- (a)  $\frac{1}{\sin(a-b)} \log \left| \frac{\sin(x-a)}{\sin(x-b)} \right| + c$   
 (b)  $\frac{-1}{\sin(a-b)} \log \left| \frac{\sin(x-a)}{\sin(x-b)} \right| + c$   
 (c)  $\log \sin(x-a) \sin(x-b) + c$   
 (d)  $\log \left| \frac{\sin(x-a)}{\sin(x-b)} \right| + c$

$$161. \text{ The value of the integral } \int_0^a \frac{x^4 dx}{(a^2 + x^2)^4} \text{ is}$$

- (a)  $\frac{1}{16a^3} \left( \frac{\pi}{4} - \frac{1}{3} \right)$  (b)  $\frac{1}{16a^3} \left( \frac{\pi}{4} + \frac{1}{3} \right)$   
 (c)  $\frac{1}{16} a^3 \left( \frac{\pi}{4} - \frac{1}{3} \right)$  (d)  $\frac{1}{16} a^3 \left( \frac{\pi}{4} + \frac{1}{3} \right)$

162. The solution of the differential equation

$$(x^2 - yx^2) \frac{dy}{dx} + y^2 + xy^2 = 0 \text{ is}$$

- (a)  $\log \left( \frac{x}{y} \right) = \frac{1}{x} + \frac{1}{y} + c$   
 (b)  $\log \left( \frac{y}{x} \right) = \frac{1}{x} + \frac{1}{y} + c$   
 (c)  $\log(xy) = \frac{1}{x} + \frac{1}{y} + c$   
 (d)  $\log(xy) + \frac{1}{x} + \frac{1}{y} = c$

163. The solution of the equation  $\frac{dy}{dx} = \frac{x+y}{x-y}$  is

- (a)  $c(x^2 + y^2)^{1/2} + e^{\tan^{-1}(y/x)} = 0$   
 (b)  $c(x^2 + y^2)^{1/2} = e^{\tan^{-1}(y/x)}$   
 (c)  $c(x^2 - y^2) = e^{\tan^{-1}(y/x)}$   
 (d) None of the above

164. A vertex of a feasible region by the linear constraints  $3x + 4y \leq 18$ ,  $2x + 3y \geq 3$  and  $x, y \geq 0$ , is

- (a)  $(0, 2)$  (b)  $(4.8, 0)$   
 (c)  $(0, 3)$  (d) None of these

165. For the LP Problem  $\text{Min } z = 2x + y$  subject to  $5x + 10y \leq 50$ ,  $x + y \geq 1$ ,  $y \leq 4$  and  $x, y \geq 0$ , then  $z$  is

- (a)  $0$  (b)  $1$   
 (c)  $2$  (d)  $12$

166. The vector equation of the plane passing through the origin and the line of intersection of the planes  $\vec{r} \cdot \vec{a} = \lambda$  and  $\vec{r} \cdot \vec{b} = \mu$ , is

- (a)  $\vec{r} \cdot (\lambda \vec{a} - \mu \vec{b}) = 0$  (b)  $\vec{r} \cdot (\lambda \vec{b} - \mu \vec{a}) = 0$   
 (c)  $\vec{r} \cdot (\lambda \vec{a} + \mu \vec{b}) = 0$  (d)  $\vec{r} \cdot (\lambda \vec{b} + \mu \vec{a}) = 0$

167. The angle between the lines

$$\frac{x+4}{1} = \frac{y-3}{2} = \frac{z+2}{3} \text{ and } \frac{x}{3} = \frac{y-1}{-2} = \frac{z}{1} \text{ is}$$

- (a)  $\sin^{-1} \left( \frac{1}{7} \right)$  (b)  $\cos^{-1} \left( \frac{2}{7} \right)$   
 (c)  $\cos^{-1} \left( \frac{1}{7} \right)$  (d) None of these

168. If  $f(x) = 2x^3 - 21x^2 + 36x - 30$ , then which one of the following is correct ?

- (a)  $f(x)$  has minimum at  $x = 1$
- (b)  $f(x)$  has maximum at  $x = 6$
- (c)  $f(x)$  has maximum at  $x = 1$
- (d)  $f(x)$  has no maxima or minima

169. The eccentricity of the hyperbola can never be equal to

- (a)  $\sqrt{\frac{9}{5}}$
- (b)  $2\sqrt{\frac{1}{9}}$
- (c)  $3\sqrt{\frac{1}{8}}$
- (d) 2

170. If the line  $y = 2x + \lambda$  be a tangent to the hyperbola  $36x^2 - 25y^2 = 3600$ , then  $\lambda$  is equal to

- (a) 16
- (b) -16
- (c)  $\pm 16$
- (d) None of these

171.  $\sim(p \vee q) \vee (\sim p \wedge q)$  is logically equivalent to

- (a)  $\sim p$
- (b)  $p$
- (c)  $q$
- (d)  $\sim q$

172. For the circuit shown below, the Boolean polynomial is

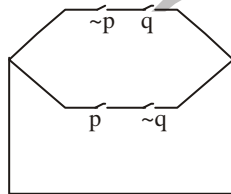

- (a)  $(\sim p \vee q) \vee (p \vee \sim q)$
- (b)  $(\sim p \wedge q) \wedge (p \wedge \sim q)$
- (c)  $(\sim p \wedge \sim q) \wedge (q \wedge p)$
- (d)  $(\sim p \wedge q) \vee (p \wedge \sim q)$

173. If the standard deviation of the observations  $-5, -4, -3, -2, -1, 0, 1, 2, 3, 4, 5$  is  $\sqrt{10}$ . The standard deviation of observations 15, 16, 17, 18, 19, 20, 21, 22, 23, 24, 25 will be

- (a)  $\sqrt{10} + 20$
- (b)  $\sqrt{10} + 10$
- (c)  $\sqrt{10}$
- (d) None of these

174. Three forces  $\vec{P}, \vec{Q}, \vec{R}$  are acting at a point in a plane. The angle between  $\vec{P}$  and  $\vec{Q}$ ,  $\vec{Q}$  and  $\vec{R}$  are  $150^\circ$  and  $120^\circ$  respectively, then for equilibrium, forces P, Q, R are in the ratio

- (a) 1 : 2 : 3
- (b)  $1 : 2 : \sqrt{3}$
- (c) 3 : 2 : 1
- (d)  $\sqrt{3} : 2 : 1$

175. 5 persons A, B, C, D and E are in queue of a shop. The probability that A and E are always together, is

- (a)  $\frac{1}{4}$
- (b)  $\frac{2}{3}$
- (c)  $\frac{2}{5}$
- (d)  $\frac{3}{5}$

176. Let  $f : \mathbb{N} \rightarrow \mathbb{N}$  defined by  $f(x) = x^2 + x + 1, x \in \mathbb{N}$ , then f is

- (a) One one onto
- (b) Many one onto
- (c) One-one but not onto
- (d) None of the above

177. In  $\Delta ABC$ , if  $\sin^2 \frac{A}{2}, \sin^2 \frac{B}{2}, \sin^2 \frac{C}{2}$  are in HP. then a, b, c will be in

- (a) AP
- (b) GP
- (c) HP
- (d) None of these

178. In any triangle ABC,  $\frac{\tan \frac{A}{2} - \tan \frac{B}{2}}{\tan \frac{A}{2} + \tan \frac{B}{2}}$  is equal to

- (a)  $\frac{a-b}{a+b}$
- (b)  $\frac{a-b}{c}$
- (c)  $\frac{a-b}{a+b+c}$
- (d)  $\frac{c}{a+b}$

179. The equation  $y^2 - x^2 + 2x - 1 = 0$  represents

- (a) a hyperbola
- (b) an ellipse
- (c) a pair of straight lines
- (d) a rectangular hyperbola

180. The value of  $\frac{a+b+c}{b+c+a} \cdot \frac{\omega}{\omega} + \frac{a-b}{c} \cdot \frac{\omega c^2}{\omega b^2}$  will

- (a) 1
- (b) -1
- (c) 2
- (d) -2